

TALENT

Wall Mounted Fan Flue Gas Multi-Point Water Heater

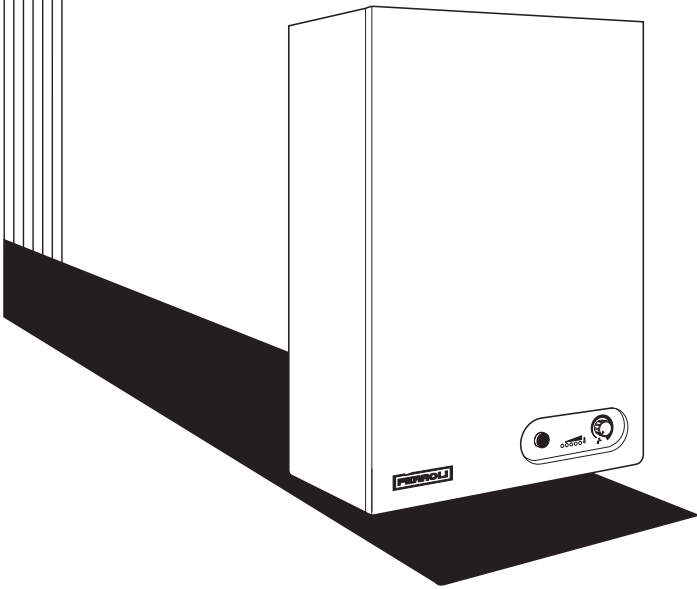

Appr. nr. B 95.06 A - CE 0063 AQ 2150

Phone numbers:

Installer _____

Service Engineer _____

Serial N° _____

Wall mounted fanned
flue Water Heater

INSTALLATION AND USE INSTRUCTIONS

Please read these Instructions
thoroughly before using
the appliance

These Instructions must be left with the appliance User.

INDEX

- 1** - General description and information
- 2** - Technical specifications
- 3** - Installation details
- 4** - Installation
- 5** - Water heater connections
- 6** - Commissioning, operation and shutdown
- 7** - Adjustments
- 8** - Converting to L.P.G.
- 9** - Maintenance requirement
- 10** - Handing over to user

1. GENERAL DESCRIPTION AND INFORMATION

1.1 Information

1. Installation must be carried out by a competent person, and in accordance with the relevant requirements of the current issues of:
 - A. Gas Safety (Installation & Use) Regulations. 1994
 - B. Building Regulations.
 - C. Building Standards (Scotland) Regulations.
 - D. I.E.E. Wiring Regulations.
 - E. Bye-laws of the local water undertaking.

Guidance on Installation is provided in this booklet, but due account must be taken of the detailed recommendations of the current issues of:

BS 5440 Part 1: Flues.

BS 5440 Part 2: Ventilation.

BS 5546: Domestic hot water.

BS 6700: Water supply.

BS 6891: Gas supply.

For installation in timber framed buildings, refer to the British Gas Publication **Guide for gas installation in timber framed housing - REF DM2**.

2. It is essential that the Water Heater be installed strictly in accordance with these Instructions and the documents, detailed above.
3. To avoid the possibility of injury, care must be taken when handling sheet metal components.

1.02 Introduction

The **Gas Multi Point** water heater is a “room-sealed” appliance: it takes in the air required for combustion and encloses all the combustion products in an hermetic compartment. The discharge of fumes and intake of combustion air are managed through air/flue pipes that may be run horizontally in all directions, or through a concentric flue running vertically or horizontally.

The main components of the water heater are:

- A compact heat exchanger in copper, formed by four pipes with external finning and internal turbulence activators.
- An insulated combustion chamber to reduce heat loss and thus improve efficiency.
- Four stainless steel burners, an oxidation and thermal shock-resistant material specially developed for this product.
- A fan to discharge combustion products and draw in combustion air.

- A high limit thermostat
- A steel room-sealed compartment treated against corrosion, enclosing components.
- An air differential pressure switch which, to ensure safe operation, allows burner ignition only when the fan functions normally.
- A newly-designed gas ignition valve assembly, comprising a fully modulating gas valve and a flame control device. (Ignition is by an intermittent pilot flame; at the moment a hot water tap is opened, a pilot flame is sparked electronically which lights the main burners.)
- A flowmeter.
- A modulating device which controls the gas valve during use in response to the signal from the flowmeter, the preset temperature and the desired flow rate (water temperature is kept constant with no waste due to temperature fluctuation).
- A water temperature control which allows the user to set the desired temperature - between 40°C and 55°C.
- Five LEDs: one green signalling that the water heater is on, and four yellow displaying water temperature.
- A temperature sensor.

2. TECHNICAL SPECIFICATION

2.01. Technical Data

Model

TALENT

	Natural gas (G20)		Propane LPG (G31)	
	Max	Min	Max	Min
Nominal Heat Input (Gross C.V.)	kW 29.7	kW 11.5	kW 29.0	kW 11.3
Nominal Heat Input (Net C.V.)	kW 26.8	kW 10.4	kW 26.8	kW 10.4
Nominal Heat Output	kW 24.4	kW 9.7	kW 24.4	kW 9.7

		Natural Gas (G20)	LPG (G31)
Pilot Injector		38/36 A	0.25 P
Ø Main Injector	mm	2.25	1.40
Ø Gas pipe connection		3/4"	3/4"
Quantity of main injectors	N _i	4	4
Gas Inlet Working Pressure	mbar	20	37
Gas pressure at Main Burners	min mbar	2	6
	Max mbar	12.2	36
Gas Flow	m ³ /h	2.83	-
	kg/h	-	2.07

Water Flow Rate	~t 25 jC	l/min	14
	~t 35 jC	l/min	10
Maximum Pressure		bar	10
Adjustable Temperature	min	jC	40
	Max	jC	55
Ø Water connections			1/2"

Dimensions	Height	mm	700
	Width	mm	420
	Depth	mm	273
Weight		kg	33
Supply voltage		V/Hz	230/50

2.02. Dimensions and Measurements

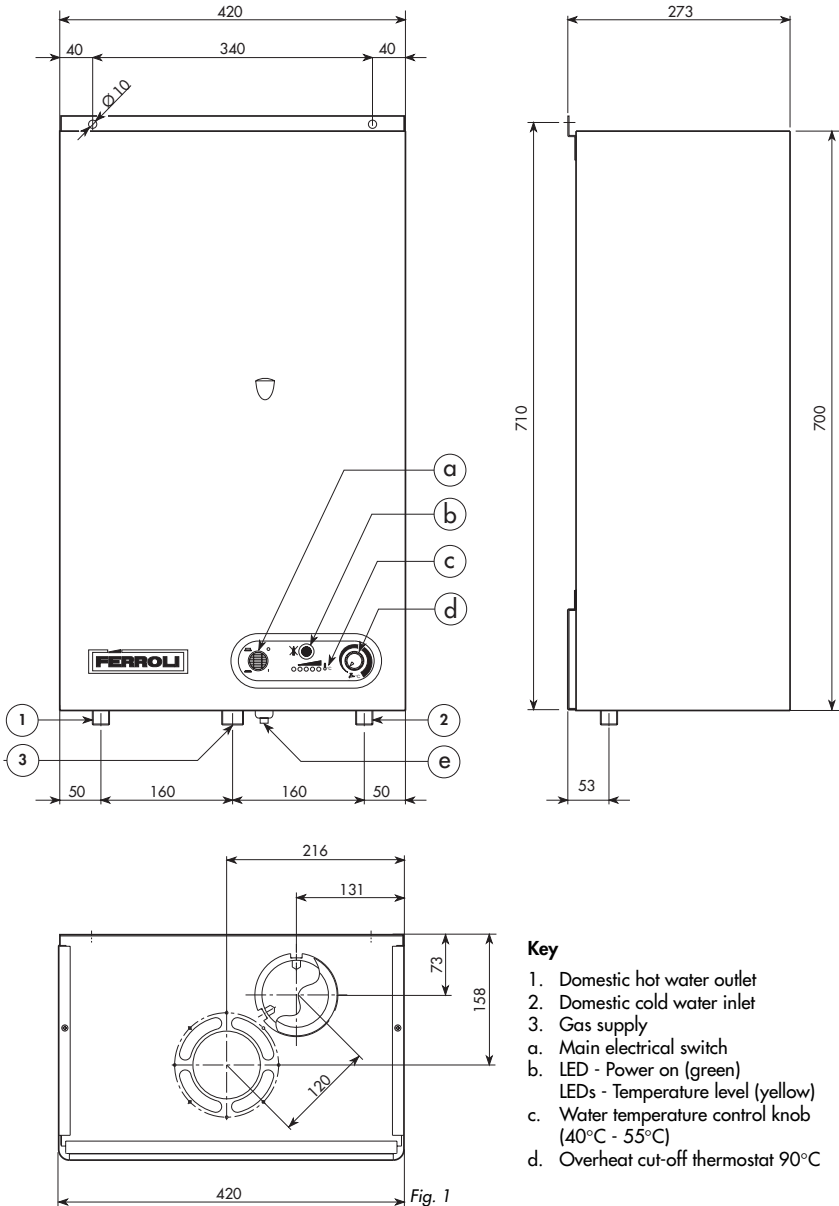

- Key**
1. Domestic hot water outlet
 2. Domestic cold water inlet
 3. Gas supply
 - a. Main electrical switch
 - b. LED - Power on (green)
 - c. Water temperature control knob (40°C - 55°C)
 - d. Overheat cut-off thermostat 90°C

2.03. Flow Diagram

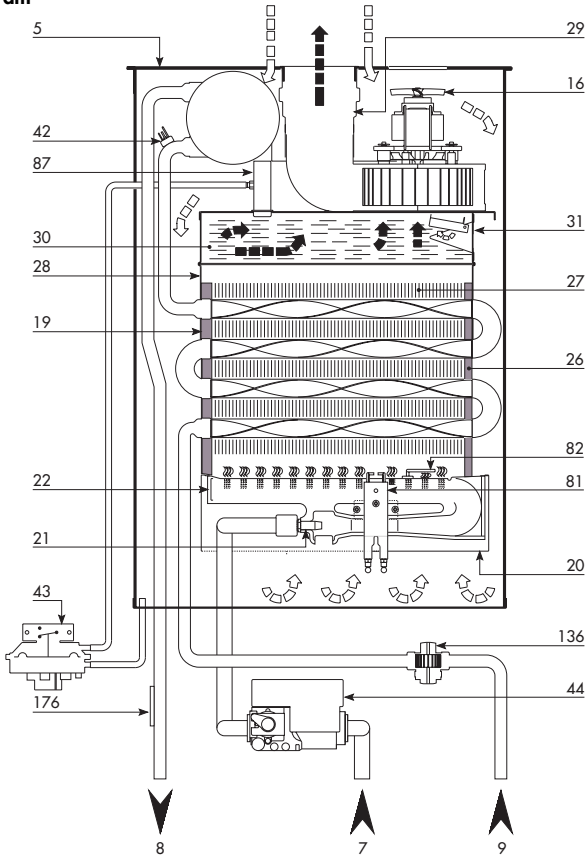

Fig. 2

- | | |
|----------------------------------|--------------------------------------|
| 5 Room-sealed compartment | 28 Flue gases collector |
| 7 Gas inlet | 29 Internal flue exit |
| 8 Domestic hot water outlet | 30 Surplus air collector |
| 9 Cold water inlet | 31 Air pressure control damper |
| 16 Fan | 42 Temperature sensor |
| 19 Combustion chamber | 43 Air pressure switch |
| 20 Burner assembly | 44 Combination gas valve |
| 21 Main injector | 81 Spark electrode |
| 22 Burner | 82 Sensor electrode |
| 25 Pilot | 87 Venturi pressure test point |
| 26 Combustion chamber insulation | 136 Flowmeter |
| 27 Copper heat exchanger | 176 Overheat cut-off thermostat 90°C |

3.0 INSTALLATION DETAILS

3.1 Gas Safety (Installation & Use) Regulations: 1994

In the interest of safety, it is the law that all gas appliances are installed by a competent person in accordance with the above Regulations, Building Regulations/Building Standards Scotland, Codes of Practice, current I.E.E. Regulations and the byelaws of the Local Water Undertaking. Failure to comply with the Regulations may lead to prosecution; it is in your interest and that of safety to ensure that the law is complied with.

Important - If the water heater is to be fitted in a timber framed building it should be fitted in accordance with the British Gas publication; Guide for Gas Installation in Timber Frame Housing; Reference DM2. If in doubt advice must be sought from the Local Gas Region of British Gas Plc.

3.2 Location of the water heater

The installation of the **TALENT** must be on a suitable non-combustible load bearing wall which will provide an adequate fixing for the boiler mounting bolts. The location should be in an area where the water pipes will not be subjected to frost conditions. In siting the water heater the following limitations **must** be observed:

The water heater may be installed in any room or internal space, although particular attention is drawn to the requirements of the current, i.e. wiring regulations and in Scotland the electrical provisions of the building regulations applicable in Scotland, with respect to the installation of the water heater in a room or internal space containing a bath or shower.

Where a room sealed appliance is installed in a room containing a bath or shower any electrical switch or appliance control utilising mains electricity, should be so situated that it cannot be touched by a person using the bath or shower.

3.3 Terminal Position

POSITION	MINIMUM SPACING (fig. 3)	mm
A	Directly below an openable window, air vent, or any other ventilation opening	300
B	Below gutters, soil pipes or drainpipes	75
C	Below Eaves	100
D	Below a Balcony	100
E	From vertical drainpipes or soilpipes	75
F	From internal or external corners	100
G	Above adjacent ground or balcony level	100
H	From a surface facing the terminal	600
I	Facing another terminal	1.200
J	From opening (door/window) in carport into dwelling	1.200
K	Vertically from a terminal on the same wall	1.500
L	Horizontally from a terminal on the same wall	300
N	Below carport	600

A Quinell Barrat and Quinell guard (part. No. C2) should be screwed to the wall centrally over the terminal, when the distance is less than 2 m from the outside floor.

3.4 Air Supply

The room in which the boiler is installed does not require a purpose provided vent.

Terminal Position

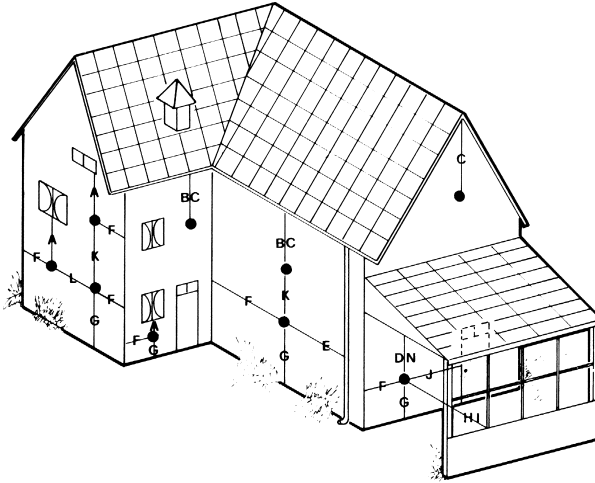

Fig. 3

Minimum Clearance mm

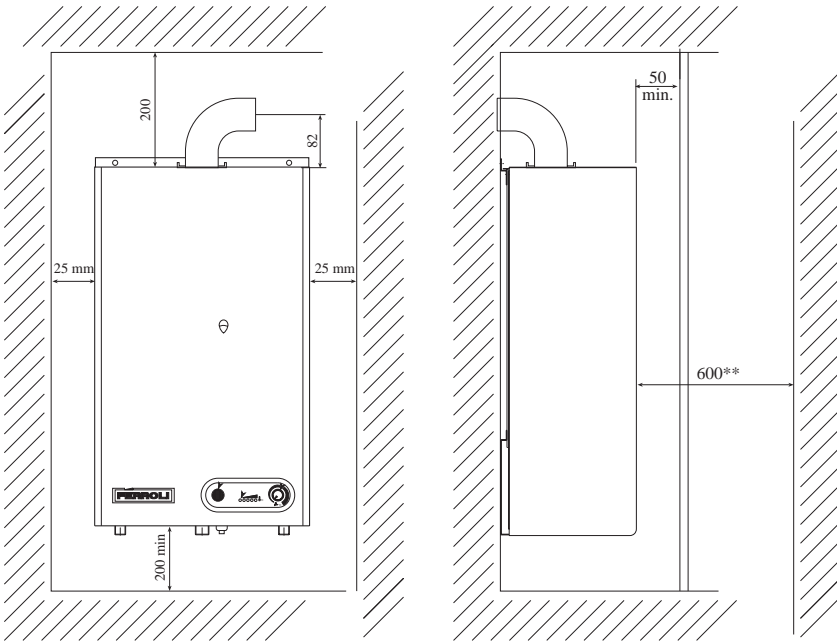

Fig. 4

NOTES

** Access to the front of the boiler must be available for maintenance (min. 600 mm).

3.5 Flue system

The water heater allows the flue outlet to be taken from the rear of the water heater or from either side. A standard flue length of 0.75 metres is provided. Alternative lengths of two or three metres can be supplied.

It is absolutely **essential**, to ensure that products of combustion discharging from the terminal cannot re-enter the building, or enter any adjacent building, through ventilators, windows, doors, natural air infiltration, or forced ventilation/air conditioning.

3.6 Gas Supply

If necessary the local Gas Region should be consulted, at the installation planning stage, in order to establish the availability of an adequate supply of gas.

An existing service pipe must **not** be used without prior consultation with the Local Gas Region.

A gas meter can only be connected by the Local Gas Region, or by a Local Gas Region's Contractor.

Installation pipes should be fitted in accordance with BS6891-1988.

Appliance inlet working pressure must be 20 mbar MINIMUM.

Pipework from the meter to the boiler must be of an adequate size (3/4" or 22 mm).

Do not use pipes of a smaller size than the boiler inlet gas connection.

The complete installation must be tested for gas soundness and purged as described in BS6981-1988.

All pipework must be adequately supported. An isolating gas valve is provided and should be fitted.

3.7 Water supply

Facing the appliance the cold water inlet is on the right with the hot water outlet on the left.

The maximum domestic water pressure for the inlet supply is 10 bar (145 P.S.I.). If the cold mains supply exceeds 5 bar (72 P.S.I.), a water governor or pressure reducing valve must be fitted in an accessible position preferable between 3 and 5 metres before the appliance.

Such a valve must be approved by the water research council.

Attention - Is drawn to the Model Water Byelaws.

Fittings manufactured from duplex (alpha-beta) brass are not acceptable for underground use and certain water undertakings will not accept their use above ground.

4. INSTALLATION

4.1 Unpacking

The appliance is delivered in 2 cartons.

4.1.1 The large carton contains the boiler, and the Installation/Serviceing and Users Instructions.

4.1.2 The second carton contains the wall fixing bolts (x2), flue assembly, water heater bend and gas cock.

4.2 Wall mounting

After selecting a suitable place for the water heater, mark location for fixing holes. Using 8 mm drill, drill 60 mm deep holes to accept fixing bolts and insert. Tighten nuts until secure, then remove nuts leaving studs protruding, hang water heater and refits nuts to secure.

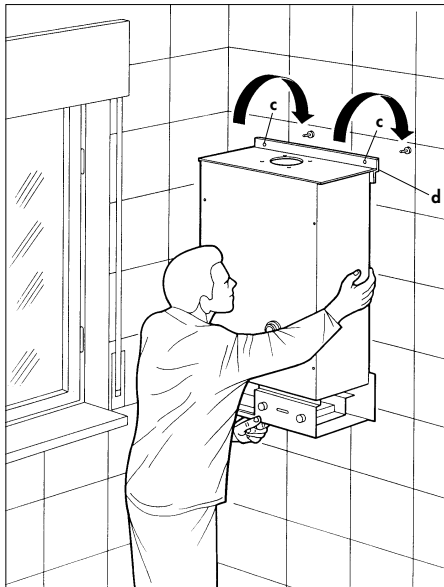
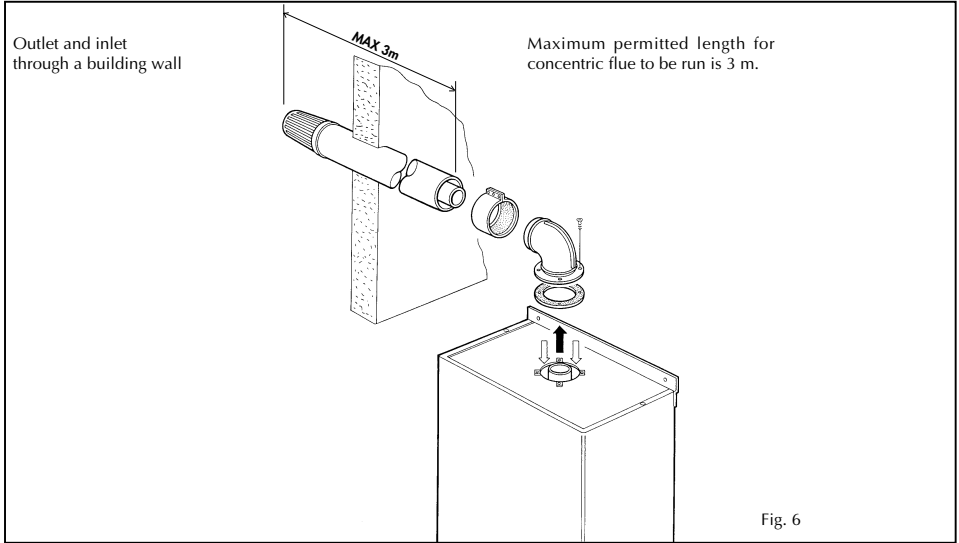

Fig. 5

4.3 Preparing the flue assembly

The water heater is supplied with 0.75 m of concentric flue which can be run from either side or to the back of the appliance. If a longer flue is required 2 m and 3 m lengths are available.

An example of using the concentric flue.



Flue connection

Drawing below shows how concentric flue should be assembled - the main points being:

1. Inner flue pipe (aluminium) needs to be 85 - 90 mm longer than plastic air intake pipe
2. The air intake (plastic) pipe only butts to the elbow
3. Care must be taken not to dislodge "O" rings

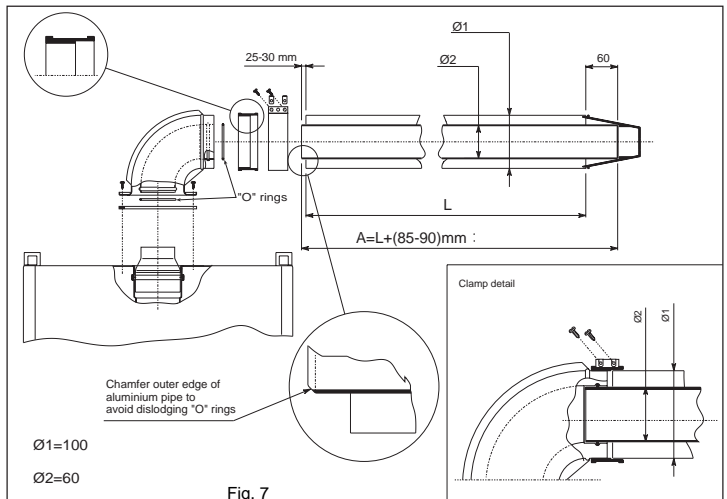

5. Water heater connections

Gas, Water and Electrical

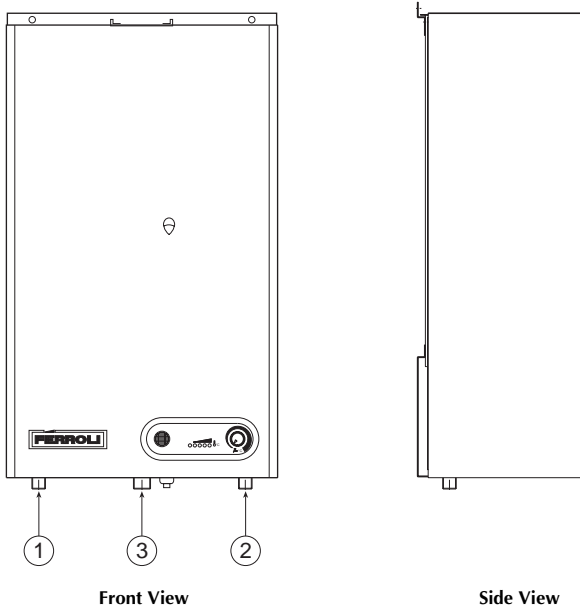

1. Hot water outlet 1/2"
2. Cold water inlet 1/2"
3. Gas Supply 3/4"

5.1 Gas supply

1. Further guidance: BS 6891, BS 6798, Gas Safety (Installation and Use) Regulations 1994.
2. Ensure the supply pipe, the gas meter and existing or new pipework will serve the maximum gas rate of all the appliance served by that meter.
3. An inlet working pressure of 20 mbar will be required at the boiler.
4. Always test for soundness of gas supply pipes in accordance with BS 6891.
5. Fit gas cock supplied upstream from the appliance.

5.2 Connecting to the water system

- The connection to the domestic water supply system should be compatible with the specifications and rating of the water heater.
- When connecting to a hard water supply, you should install a softener device to reduce the frequency of the heat-exchanger blockages and maintain an optimal output.
- Connect the water heater to the water supply system and fit in a water tap upstream from the appliance.

- Facing the appliance, the cold water inlet is on the right, the hot water outlet is on the left.

Make sure the cold and hot water systems do not serve for earthing of the electric or telephone systems. They are not designed for this purpose. Such use might cause within a short time serious damages to the plumbing and appliance.

5.3 Electric supply

The water heater should be powered by a single-phase 230V-50Hz current, with a 3A fuse (set between the main power line and the water heater) and a two-pole switch with cutoff opening of 3 mm or more.

Connect the power cable provided to the main power line **matching with the line, neutral and grounding wires**.

If the water heater is installed in a room containing a bath or shower any electrical switch or appliance control utilising mains electricity, should be so situated that it cannot be touched by a person using the bath or shower.

Ferrol disclaims any liability for damages to persons, animals or property caused by lack of earthing of the heater or by an electrical system which does not comply with current regulations.

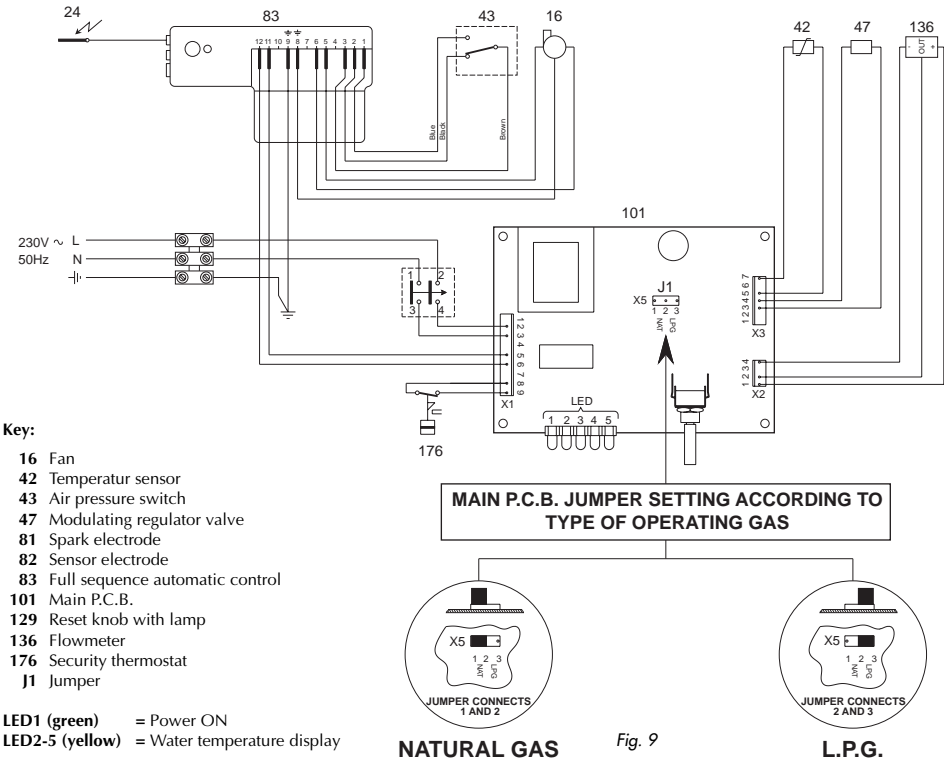

Fig. 9

6 COMMISSIONING, OPERATION AND SHUTDOWN

6.1 Tests to be performed prior to first start

Before starting the water heater for the first time you should check the following:

- That the gas and water taps upstream of the water heater, are open.
- That there are no gas or water leaks along the lines or in the appliance.
- That electric connections have been performed properly (paying the closest attention to matching line and neutral wires) and that the appliance is correctly earthed..
- That there are no inflammable liquids or materials in the immediate vicinity of the appliance.
- That the gas pressure and gas flow are at the required levels.
- That the air inlet and flue gases exhaust pipes are properly connected (flue installation).
- That all hot water taps are turned off.

6.2 Commissioning

- Turn on the power.
- Set the switch on the instrument panel to "On" (the green LED should light up).
- Open a hot tap to draw water this will automatically activate the fan to start discharging combustion products. The electronic device on the gas unit activates an electrode which ignites the pilot flame and simultaneously verifies the completion of the ignition phase and allows the lighting of the main burner.
- In the event ignition of the pilot flame has failed, check the line and neutral connections for correct polarity.

6.3 Operation

Talent is a water heater designed for prompt production of hot water.

During drawing of domestic water, the flowmeter sends a signal to the electronic device which, in response to the preset temperature and the desired flow, adjusts the gas valve. The water temperature is thus kept constant and this eliminates the waste due to temperature fluctuation.

The user may select a temperature between 40°C and 55°C using the knob on the instrument panel.

The diagram in Fig. 10 shows the water heater temperature range, within which it may operate.

DIAGRAM OF WORK RANGE AS A FUNCTION OF SET TEMPERATURE

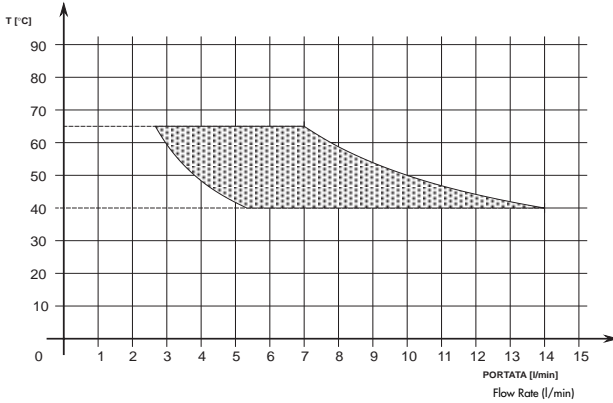

- Results are based on incoming water temperature of 15°C.
- Temperature may be set from a minimum of 40°C to a maximum of 55°C.

Fig. 10

6.4 Shutdown

To shut down the appliance turn the power supply off (switch *), and turn off the gas supply cock.

Note: You should shut down the appliance whenever you intend not to use it for a long period of time. During long winter breaks, you should drain the water out of the water heater to avoid damage that might be caused by freezing.

7. ADJUSTMENTS

The TALENT water heater is factory set and no adjustments are normally required, however the following adjustments can be made if problems are found.

7.1 Adjusting the pressure and flow rate at the main burner

This appliance, being of the modulating-flame type, comes with two fixed pressure settings - for minimum and maximum, as shown in the table - for each type of operating gas.

Remember: You should adjust the minimum pressure setting first to ensure a correct ignition of the burner, then proceed to adjust the maximum pressure setting. Any adjustment of the minimum pressure modifies the maximum setting. The following adjustments, given their extreme sensitivity, should be carried out solely by company expert personnel.

7.2 Adjusting the minimum and maximum pressure settings

Start with an ignited burner:

- Connect an appropriate manometer to the burner pressure test point.
- Disconnect the power supply wires leading to the "Modureg" coil "c".
- Disconnect the pressure balancing pipe "h"
- Remove the protection cap "d" fitted on top of the coil.

- Regulate the minimum pressure by turning nut "e", anticlockwise to reduce it and clockwise to increase it.
- Turn the burner off three or four times by closing and opening the gas cock, checking every time that the pressure level corresponds to the new setting and that the burner ignites normally. If that is not the case, an additional adjustment is required.
- Upon completing this procedure, check the maximum pressure level.
- Wait until the pressure reading in the manometer has stabilized.
- Carefully press all the way down the pin "f" and keep it pressed. If you wish to adjust the maximum pressure setting, turn slowly the regulating nut "g", clockwise to increase it and counterclockwise to reduce it.

After adjusting the maximum and minimum pressure settings, reconnect the wires to the Modureg coil "c", re-attach the pressure balancing pipe "h" and replace the protection cap "d". Now the water heater is set for automatic operation. Remove manometer and check for gas soundness.

Note: If the "Modureg" coil fails to respond you must replace the complete "Modureg" unit. Any attempt to replace only the coil might cause damage to the "Modureg" calibration.

Any adjustment made using the regulating screws should be carried out with caution.

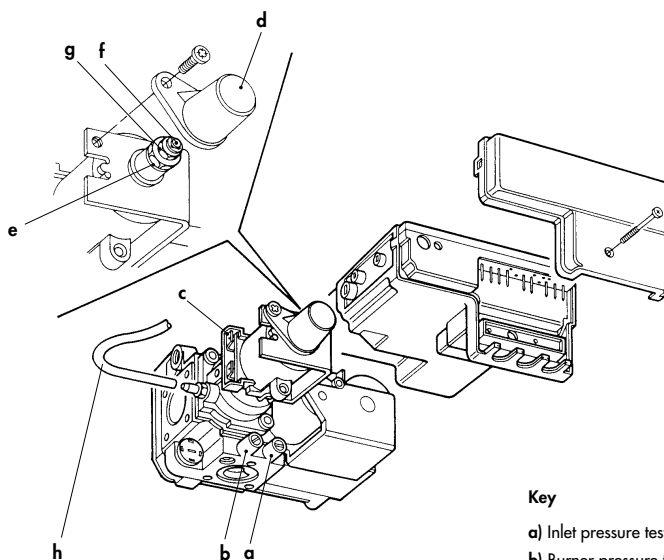

Key

- a) Inlet pressure test point
- b) Burner pressure test point
- c) Electric coil connection
- d) Protection cap
- e) Minimum pressure regulating screw
- f) Maximum pressure pin
- g) Maximum pressure regulating screw
- h) Pressure balancing pipe

Fig. 11

8. CONVERTING FROM ONE OPERATING GAS TO ANOTHER

The following conversion and adjustment procedures are to be performed solely by qualified personnel. Ferrolì disclaims any liability for any material and/or personal damages caused by tampering with the appliance by unauthorized persons. If the appliance must be used with a different type of gas, convert it as follows.

To convert the appliance from Natural gas use to Propane use and vice versa, you must change the main injectors, adjust the maximum and minimum pressure settings of the gas valve (see related chapter), adjust the start-up "step" as shown in fig. 12, ensuring that the jumper on the electronic board is set as shown in fig. 9.

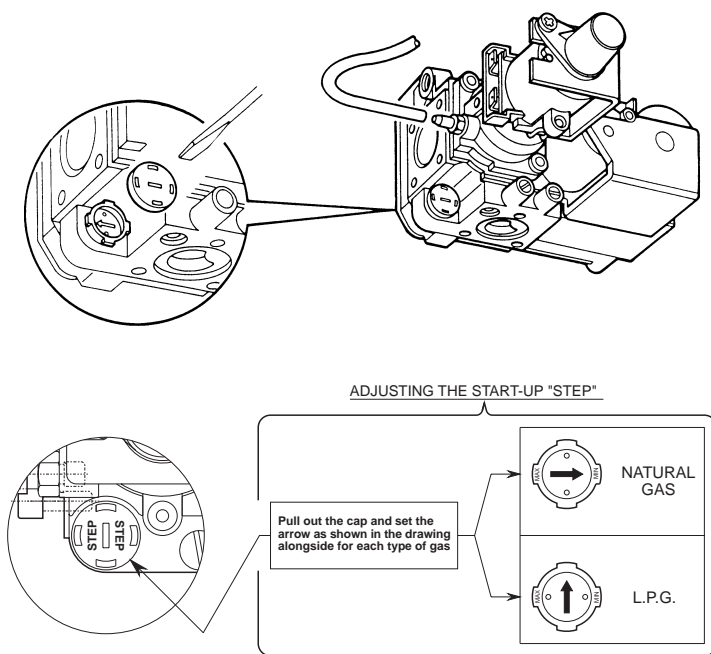

Fig. 12

9. MAINTENANCE REQUIREMENT

For continued reliable use it is a good practice to have a qualified person check the appliance at least once a year.

Prior to performing any work related to cleaning, maintenance and opening or removing panels of the water heater, shut the power down (by turning the main electric switch off), and turn off the gas cock. To remove the casing unscrew the four screws "a" and proceed as shown in fig. 13.

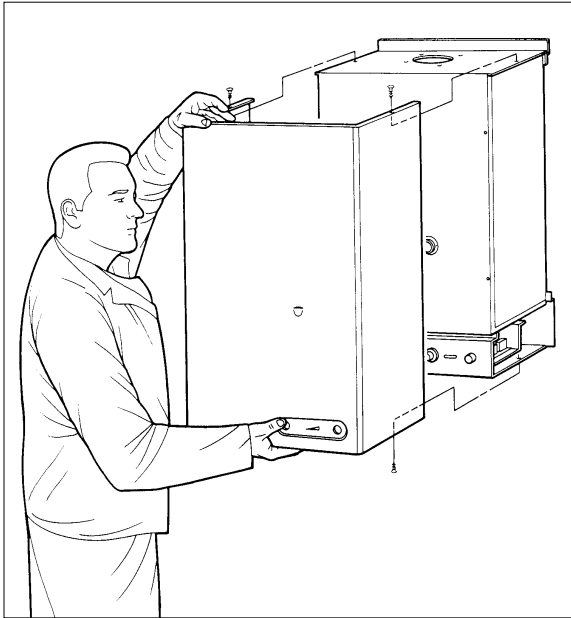

Fig. 13

10. HANDING OVER TO USER

- A. Explain operation of the water heater and hot water control
- B. Advise against obstruction of purpose provided ventilation and of the flue terminal
- C. Give advice on frost protection and turning off the appliance
- D. Advice on importance of annual service
- E. Hand all instructions and literature to the user.

Phone numbers:

Installer _____

Service Engineer _____

**BECAUSE OF OUR CONSTANT ENDEAVOUR FOR IMPROVEMENT DETAILS
MAY VARY SLIGHTLY FROM THOSE QUOTED IN THESE INSTRUCTIONS.**



ALL SPECIFICATIONS SUBJECT TO CHANGE

Stockton Close, Minworth Industrial Park, Minworth, Sutton Coldfield, West Midlands B76 8DH
Tel.: 0121/3523500 - Fax 0121/3523510
